

Obsessive-compulsive Paraphilias Viewed as a Sub Type (OCD) Spectrum Disorder: A Hypothetical Bio-Social Model

Edward D. Balyk, Ph.D.¹

Since the 1970's, and perhaps even earlier, America has been suffering the effects of an epidemic pathological phenomenon eating away at the very core of our society. Virtually everyone is alarmed and panicky, we make new laws, build more jails and spend billions of dollars a year, and yet the sex offender (paraphilia) epidemic continues to expand exponentially. In this article, we will explore, the why, how, and what to do. We will discard old fashioned, 'good intention' type therapeutic approaches and armed chair speculations for a modern 21st century bio-medical model for these devastating disorders. We will abandon the criminal model and move toward a bio-medical model.

A neurobiological model of obsessive-compulsive paraphilia (OCP) is essential in the effective diagnosis and treatment of these disorders. The pathophysiological model is essential in medical practice as it provides an understanding of clinical symptomatology and a common rational basis for therapeutic intervention, a model that is tragically missing in the diagnosis and treatment of paraphiliological disorders, which relies on a hodgepodge of good intentions rather than a rational bio-medical model. In fact, it is sad to say, that there is no established model or rationale for the diagnosis and treatment of these highly resistant and debilitating disorders. It is the author's primary intention to develop a bio-medical diagnostic and treatment model in this article, at least to begin a rational seminal effort, which will hopefully be continued by others in the future.

An explanation for the clinical manifestations and the therapeutic response of

different interventions of an illness based on the anatomy and physiology of the diseased system is the essential requirement in the modern clinical practice of medicine, and should extend to the psychiatric and psychological specialties as well. The paraphiliological disorders are believed to be pathological, as any other biological system is in pathological states. The central nervous system (CNS) is believed affected by the disorders that we shall call OCP. The reader should keep in mind that DSM IV does not contain the OCP nosology at this time. The author is using this term as a hypothetical term to explain symptoms that appear similar to OCD from many years of personal clinical experience.

DSM IV lists several forms of paraphilic disorders such as masochism, sadism, voyeurism, exhibitionism, and pedophilia.¹ Some types of sexual fetishism may also be classified as paraphilia. However, the author has catalogued some thirty different types. In this article we will address only rape or (raptophilia) sexual arousal and orgasm maximized by force and humiliation, and pedophilia (sexual craving for children). Each paraphilia is unique because it is fused or encoded to a particular sexual erotic ritualistic behavior, or object, as a contingency requirement for maximum sexual gratification, which is socially and legally unacceptable.² The object or target of the ritualistic behavior may be the subject of fantasy, or in vivo behavior, or both.

Another feature of paraphilic disorders is that the fantasy or ritual attack may occur several times in a very ritualistic fashion during sexual arousal, or as part of the foreplay leading to sexual erotic arousal

1. 23 Cottage Place Keansburg, NJ 07734

and ultimately orgasm.³

In more than a decade of clinical research, the author has catalogued some thirty different paraphilias, each with content specific rituals and behaviors, in the express service of sexual erotic arousal and orgasm. Only two of them will be described in this article, the remainder will be presented in a future article. The repetitive, ritualistic behaviors of paraphilia are very similar to the uncontrollable rituals observed in obsessive-compulsive disorder (OCD). An important difference between OCP and OCD is the component of sexual stimulation and orgasm seen with OCP that is not found in OCD.⁴ Like patients suffering OCD, OCP patients often have co-morbid personality disorders and or other medical conditions which also require appropriate professional attention perhaps simultaneously.⁵ Thus, it appears fairly reasonable to assume there may be anatomical similarities between OCP and OCD, such that models proposed for OCD may help explain OCP. On clinical grounds, the author hypothesizes that OCP is one of the spectrum of OCD disorders.⁶ Because there are putative neurobiological models of OCD, an attempt will be made to apply current knowledge about OCD to OCP.^{7,8}

Our discussion will be divided into several parts. First, a comparison will be made among the clinical manifestations of OCD and OCP. Next, an integrated hypothetical neurobiological model of OCD will be presented. It will then be shown how the phenomena of OCP may be sharing similar neurobiological systems as OCD. Finally, the difference between OCP and OCD will be discussed with particular reference to serotonin, obsession, compulsion, faulty cognition and orgasm.

Clinical Comparisons Between OCP and OCD

According to DSM IV, a compulsion is defined as a 'ritualistic behavior', or mental act that the person feels driven to per-

form or think, regardless of normal logic or reason.⁹ In this author's clinical experience, when individuals suffering paraphilic disorders are questioned as to how they would define their behavior, the above definition fits quite well. As with compulsions and obsessions, the behavior of the paraphiliac contains content-specific rituals with well-defined mental or behavioral sequences.

Because of the apparent similarities between the paraphilias and OCD, it may be possible to understand why an otherwise 'reasonable' individual who operates fairly rationally in other aspects of his life, will act completely irrationally to a particular sexual-erotic stimulus.¹⁰ Elsewhere, it has been stated that the content-specific rituals of OCD seem like pre-packaged sequences of behaviors that are executed upon trigger by a stimulus. These 'pre-packaged' sequences seem similar to computer programs known as Macro's.¹¹ For example, the compulsive hand washer is driven to access the Macro of his hand-washing ritual by a trigger such as a handshake, due to some experientially encoded fear of 'contamination'. The encoded fear of 'contamination' creates anxiety which is a dysphoric emotional state relieved by the obsessive-compulsive ritual, at least temporarily. Anxiety may be defined as a psychophysiological state of dysphoria produced by an encoded fear to a particular bio-social stimulus.¹² The design of the Macro is based on past experiences relating to, or associated with, 'contamination' from handshaking, touching sticky surfaces, or other ordinary daily rituals involving touching objects.

Thus, encoded fears and the counter rituals that are developed to deal with them seem irrational to all but the patient. This suggests a dual nature to obsessive-compulsive behavior, the obsessive fear and the compulsive act. The fear seems to create the anxiety, while the act is an effort to counter it. As will be explained later, most obsessive-compulsive fears are fused or

Obsessive-compulsive Paraphilias Viewed as a Sub Type (OCD) Spectrum Disorder

coded molecularly to the rituals, such that any bio-social stimuli in the repertoire of possible bio-social codes will trigger hand washing rituals in the manner of a Macro that offers no other alternative behavior for the patient. This seems true because patients avoid triggers of obsessional fears knowing that rituals will come in their wake.¹³

Paraphilias present with similar irrational rituals as OCD. At the core of any paraphilia is usually some type of encoded doubt or fear combined with some form of ritualistic sexual behavior although paraphilic rituals can, and often are, encoded solely for sexual arousal and orgasm. For example, in one patient in the author's experience, a compulsive exhibitionist had a fear that he was inadequate in adult heterosexual intercourse, so he said, but derived superb sexual gratification by shocking and causing fright in unsuspecting females that he found sexually attractive. Orgasm reduced all anxiety over any subjective sexual inadequacy.¹⁴ In paraphilic exhibitionism sexual arousal was apparently fused to the act of genital exhibitionism in front of unsuspecting female targets. The shock and surprise component generates intense sexual orgasm for the exhibitionist as he views the shocked response of the victim. The ritualized sequences of behavior that have been previously termed a Macro for OCD seem to exist for the paraphiliological disorders, the difference being sexual themes.

In a compulsive rapist, there appears to be an obsessive craving toward the target that requires stalking, and attacking rituals. The sexual-erotic contingency requirement for the raptophile (rapist) is violence, torture, pain, and humiliation of the target victim. Some raptophilic rituals include murder or maiming of the target victim, genitally, physically and emotionally, in order to achieve the most sublime orgasmic pleasure. Some raptophiles burn the breasts, nipples, and tear, puncture or mutilate the target victim, all in the service of sexual-erotic arousal and euphoric orgasm.

For the purpose of this paper, the Macro or ritualized sexual behavior responds to a well-defined sexual-erotic design defined as a Sexual-Erotic Arousal Pattern, or SEAP. This is similar to the ritualized compulsive behavior, or Macro, of OCD minus the sexual-erotic component. For the rapist, the compulsive SEAP is accessed as an orgasmic ritual in response to sexuo-erotic craving, (when a supreme orgasmic experience is demanded). For a pedophile, a supreme arousal and orgasm is achieved at the sight of certain kinds of children. Under such circumstances, the pedophilic SEAP is accessed when the target enters the visual field and the pedophile goes into an obsessive-compulsive craving mode, stalking his target, masturbating often several times a day. The author has quantified pedophilic craving in several chronic pedophiles on the modified Y-BOCS (Yale Brown Obsessive-Compulsive Scale, range 0 to 40). They invariably fall in the high thirty range, which is an extreme reading, meaning that the patient spends some six to eight hours a day obsessing about his pedophilic targets and masturbates, anywhere from three to ten times a day. These results will be presented in another article. Suffice it to say at this juncture, that pedophilic craving is very successfully reduced with certain SSRI (selective serotonergic reuptake inhibitors) at least in the author's pilot trials.

The Macro and the SEAP

It has been shown clinically, that patients with OCD have a high incidence of parents who suffered from panic disorder and other types of anxiety disorders often never diagnosed or treated.¹⁵ During development, such children are probably hyper-sensitized to the environment in a fear-based manner due to excessive parental encoding of fears, doubts, and paranoid types of cognitions. Such children adapt bio-socially by creating rituals based on various behaviorally encoded exposures that are associated with, or fused to, fears,

doubt and suspicion. It is likely that the paraphilic disorders are potentiated by bio-social sexuo-erotic exposures in juvenile life. It is also possible that genetic proclivities may come into play in yet unknown ways.

To illustrate, from a carefully detailed sexual history, taken from a compulsive rapist in our example, this rapist witnessed, first hand, violent, brutal sexual behavior between his mother and several of her consort lovers which became fused (encoded) as preferred sexuo-erotic arousal. Such visual exposures are believed to become coded neurobiologically as the Sexual-Erotic Arousal Pattern (SEAP). Thus, toxic childhood sexual exposures appear to become fused (via molecular encoding) with the violence and brutality creating a SEAP in an analogous fashion similar to the phenomena of imprinting.^{16, 17, 18}

The basis for the concept of the SEAP as a molecularly encoded behavior can be shown from recent neurobiological research. In Aplasia (a large jumbo shrimp) long term synaptic modulation requires synthesis of new macromolecules. (serotonin molecules are suspect).¹⁹ This has also been confirmed in higher orders of species where learning involves the *de novo* formation of molecules and neural pathways.²⁰ In addition, it has been demonstrated that neuroreceptor changes occur in response to social exposures.²¹ In this regard, a neural mechanism for plasticity in the human cortex has been postulated. The neural architecture of the cortex is susceptible to experience-dependent modifications during development that can result in lasting changes in adult neural architecture.²² MRI studies have demonstrated a fairly positive relationship between severe emotional trauma and changes in the structure of the hippocampus,²³ a key neuroanatomical region in our discussion.

Thus, the author postulates that sexual-erotic trauma, force, adventitious exposure, or simple visual exposure in childhood could cause changes in neural architecture that may result in

macromolecular generation. This hypothesis is the neurobiological basis for the SEAP. Such SEAP like Macro's may exist for both OCD and OCP disorders, molecularly encoded programs or templates of behavior that have been neurally imprinted into the cellular memory of the brain.²⁴ Supportive clinical evidence that such programs may in fact exist and be encoded and stored in the temporal lobe, as well as other brain areas, comes from several sources. Patients with the Kluver-Bucy syndrome, a temporal lobe abnormality, exhibit hypersexuality and hyper-orality. Also, when the temporal lobe is stimulated in the fully conscious epileptic patients, complex visual and auditory images are stimulated, some with strong sexual and emotional themes. In addition, during an attack of temporal lobe epilepsy, there is intensification of these kinds of reactions.²⁵ From this evidence, it seems entirely possible that all, or part, of SEAPS and OCD programs may be housed or modulated by temporal lobe neurobiological systems.

Putative Neuroanatomy

The temporal lobe is in a crucial neuroanatomic site when viewed in the context of a bio-medical model of anxiety and obsessive-compulsive disorders. One model of anxiety postulates a system that inhibits ongoing behavior in the presence of stimuli, i.e. 1) signals of danger, 2) signals of punishment, 3) signals of non-reward, 4) new or novel stimuli, or 5) innate fear stimuli. In anxiety disorders and perhaps in paraphilic disorders, these systems may be super sensitive or defective in some way; in particular the serotonergic transmitter subtype 5-Ht₁ (5 hydroxytryptamine). At present, although there are about some seven known families of serotonergic transmitters and fourteen subtypes, the one (A) subtype seems to play a principle role in OCD and the other anxiety disorders. The author speculates that OCP may be part of the same spectrum of disorders, since experimental

Obsessive-compulsive Paraphilias Viewed as a Sub Type (OCD) Spectrum Disorder

pilot trials with certain SSRIs yields positive reduction, especially in pedophilic craving. The behavioral inhibition system (BIS) is thought to access behaviors that will 'COPE' with stimuli²⁶ such as those apropos to the present discussion. The BIS is a septal-hippocampal system that accesses behavioral programs from the temporal lobe; the punitive anatomical location of SEAP programs. Also, in recent theoretical model of OCD, it is thought that there is a prefrontal cortex-basal ganglia-thalamic circuit which perservates motor behavior.²⁷ Here the BIS may offer the mechanistic link between access of the SEAP from the temporal lobe and its motor execution through connections to the prefrontal cortex-basal ganglia-thalamic circuit via the Papez circuit.²⁸ The reader is reminded again that these are hypothetical speculations which are designed to stimulate further exploration, not intended to explain causation en todo.

In this next section, we will attempt to link all three neuroanatomic systems by following a motor program, or SEAP, from its hypothetical storage in the temporal lobe to its perseverated motor execution. It should be kept in mind that both the SEAP and the Macro are variations of a normal neuropsychological process. According to our model, the BIS functions in all individuals to provide pre-programmed encoded behaviors designed to cope with anxiety producing stimuli, a fight or flight pattern, and, in our model; comorbidly coded sexual arousal behaviors (paraphiliological disorders).

If pathologically coded, the Macro or SEAP behavior perseverates or repeats itself like a broken record, out of control. This perseveration may result from neurochemical dysfunction; a good candidate is the 5-HT₁ subtype and/or neuro anatomical impairment in the BIS, the prefrontal cortex-basal ganglia-thalamic circuits or other combinations. Other transmitters could also be affected pathologically by cascading effects, because the hu-

man brain is currently known to have some two hundred transmitters and neuromodulators, all of which have been cloned. It is not likely that any single transmitter or modulator functions alone, either normally or pathologically. The BIS is a system that modulates anxiety from stimuli that 'warn of punishment' or 'non-reward' novel stimuli (sexual arousal) and innate fear stimuli. The BIS will react through inhibition of ongoing behavior, increased level of arousal and attention to the environment, especially to novel stimulation in the environment. The anatomical structure of the BIS is shown in figure 1.²⁹ The following is a summary of the BIS taken from Grey.³⁰

It includes the septal area, the hippocampal formation, Papez circuit (fig,2) which runs from the subicular area in the hippocampus to the mammillary bodies, anterior thalamus, cingulate cortex, and back to the subicular area and neocortical inputs to the septal-hippocampal system from the entorhinal area and prefrontal cortex. It is particularly supportive of our hypothesis that neurochemically, and neurobiologically there are dense populations of ascending noradrenergic and serotonergic inputs to the septo-hippocampal system; dopaminergic input to the septo-hippocampal system; noradrenergic innervation of the hypothalamus and, possibly descending noradrenergic fibers of the locus coeruleus that may also be involved in transmitter cascading effects.

It appears that the septo-hippocampal system along with the entorhinal area and the 'subicular loop' (Papez circuit) have the task of predicting sensory events to which the organism will be exposed to. Sexual and erotic stimulation can be clearly interpreted as a sensory event. If there is a coded mismatch between actual and predicted events, or if the predicted event is aversive, alternative strategies involving alternative responses will be tested, which are attempts to assist the organism cope.

The BIS is believed to produce attention to and exploration of the environment which is executed via the entorhinal area and the cingulate cortex and behavioral inhibition via the cingulate cortex and a descending projection from the lateral septal area to the hypothalamus. The hippocampal theta rhythm is believed to quantify and pace the flow of information around this system.

It is particularly interesting for our theme that the theta rhythm is strongly influenced by the effect of testosterone on the locus coeruleus which results in a decreased threshold for production of theta rhythm with resulting increase in flow of information around the BIS.³¹ The principle role of the noradrenergic projection to the septo-hippocampal system is to tag stimuli as 'important'; (i.e.) requiring particularly careful attention. As we have mentioned earlier, the ascending projections in this area are particularly innervated with serotonergic projections and if cross coded by pedophilic or other paraphilic Macro's, sexual and erotic functions may become obsessive and compulsive.

The prefrontal cortex has two principle roles. First, it transmits to the septal-hippocampal system information about ongoing motor programs to be used in the processing of predicted sensory events. Secondly, it facilitates control by the neocortex, in man, verbally coded information (that is believed to be stored in macro molecules; *vide supra*). The most likely area for the storage of sexual-erotic and anxiolytic Macro's [molecularly encoded] is the temporal lobe which is accessed by the septo-hippocampal system through pathways to the entorhinal area, and perhaps to other adjacent areas. There appears to be a functional interaction between an encoded SEAP and an OCD Macro, probably in the temporal lobe and the neocortex once a encoded program has been accessed.

The symptoms of obsessive anxiety in man are believed to arise from excessive

activity in the BIS which appears related to 5-HT₁ activity. In particular, obsessive-compulsive symptoms seem due to hyperactivity by the BIS which probably results from interactions of the septo-hippocampal system and the neocortex. Anxiolytic compounds, especially the SSRI's are effective in anxiety disorders because they modulate and normalize the activity of ascending-noradrenergic and serotonergic projections to the septo-hippocampal system.

It is hypothesized that these projections contain molecularly coded information (possible 5-HT₂ and other sub types of 5-HT transmitters). It is also believed that there is an interaction between the neocortex and the septo-hippocampal system that suggests participation of the neocortex in anxiety disorders, obsessive compulsive symptoms including our hypothetically new category of obsessive-compulsive paraphiliological disorders. This proposed neocortical dynamic will be described in the next section of this paper.

The contribution of the neocortex and the frontal lobe are particularly influential in the process of cognition. It is believed that social inhibition and concern over the consequences of actions as well as impulse control are functions of this area.³² During obsessive-compulsive ritual behavior there seems to be a loss of frontal lobe control which has been suggested to be related to defective or hypermetabolism of the medial orbital gyrus of the frontal lobe. These dynamics are fairly well established and they are believed to involve 5-HT₁ and possibly other 5-HT families of synaptic dynamics. This area seems to rivet a pathological Macro (or paraphilic SEAP) at the expense of impulse control. This area is termed the 'worry circuit' of the frontal lobe.³³ Once a Macro or SEAP is encoded or riveted into the 'worry circuit' (fig.3). It undergoes perseveration of both thoughts and behavior. It appears that a hyper-metabolic BIS, continuously repeats the encoded program of the Macro, or SEAP. In clinical practice, it is because of



Obsessive-compulsive Paraphilias Viewed as a Sub Type (OCD) Spectrum Disorder

these neurodynamics that the patient continually repeats checking behaviors for fear of not 'doing something right'. This is why obsessive compulsive disorders are often referred to as 'doubting disorders'. The paraphilic patient knows perfectly well that his paraphilic craving is increasing, but 'can't' stop it. Once obsessive craving occurs the patient is completely oblivious to laws, consequences or jail sentences. For this reason, some authors have applied the term 'paraphilic attack' to the full blown paraphilic episode. Because it is similar to an epileptic attack, when it occurs the patient is completely powerless to stop it.

The role of the male sex hormone, testosterone, may now be discussed in OCP. As mentioned previously, testosterone primes the locus coeruleus to increase theta wave activity in the BIS with the result that it increases circulation of messages around the BIS. It is believed that during sexual arousal, there is rapid processing of information around the BIS, which is believed to trigger SEAP access. The terminal point for paraphiles is sexual orgasm, because of the powerful endorphin reward which re-enforces the behavior.³⁴ It should be noted here that the BIS is thought to be hyperactive especially in regard to 5-HT₁ transmission in obsessive-compulsive and other OCD spectrum disorders³⁵ which will likely add to the likelihood of the repetition of information circulating through the BIS. The system appears to function as if thoughts and behavior proceeds too rapidly, resulting in behavioral staccato type starting and stopping, or checking and re-checking. The question now arises as to why testosterone (a sex hormone) would increase arousal of the BIS? stated earlier, innate fear stimuli' especially those that are encoded during juvenile socialization, will stimulate BIS arousal.³⁶ For example, in a rapist, pictures of, or live female targets with certain kinds of angry faces may increase anxiety and sexual erotic craving simultaneously because they are neurobiologically coded

that way. By contrast, in pedophiles the same sequence is believed to occur, the only difference is the coding of a child target. It is also interesting to note that lesions of the locus coeruleus will increase gregariousness (in rats) which is likely due to reduction in avoidance produced by the stimulus.³⁷ Thus, it is postulated that during sexual arousal, testosterone will increase in the BIS and access any other comorbidly coded program, (i.e.) a obsessive-compulsive paraphilological arousal pattern (SEAP).

It has been proposed that sexual-erotic stimuli coded in the course of dominance and socialization interactions are among the kinds of stimuli which activate the BIS.³⁸ Assuming that sexual behavior is such an interaction, then stimuli coded in the course of such social exposures are among the kinds of stimuli that will activate the BIS, provided such stimuli have been encoded molecularly (by sexual erotic exposure) or 'fused' to the interaction. During sexual arousal, (sexual-erotic maturation) the dominance of social interactions are believed to be fused to paraphilic sexual rituals. Thus, paraphilic encoding is assumed to cause the programmed, encoded BIS to access whatever SEAP, or in some cases multiple SEAPS, that it has been coded for.

During sexual-erotic arousal, a 'normal' heterosexual male manifests a craving for peno-vaginal penetration which is bonded to affection or 'love' and produces a reciprocal craving in the female that results in mutual sexual-erotic and emotional satisfaction. However, if an encoded response such as an angry face and aggression, or violence, is coded, then the sexual-erotic ritual and behavior will demand rape behavior. Such encoded programs are consistently seen in raptophiles, especially multiple exposures to brutal, violent sexual acts witnessed by mothers and paramours, or other kinds of experiences of a similar nature by other relatives, adults or possibly adolescent females. The final

adult rape ritual pattern then comes to rest in the adult SEAP of the typical raptophile when a craving for a superior sexuo-erotic response begins.

Once the paraphiliac SEAP is triggered in an individual with an encoded compulsive paraphilia, it is believed that the SEAP will perseverate in the 'Worry Circuit' of the frontal lobe until orgasm terminates the sexuo-erotic ritual. Unfortunately, the SEAP ritual or rituals becomes the end point, because it receives positive reinforcement through sexual orgasm. During the beginning stages of sexual arousal, the paraphiliac patient begins to scan for these associated encoded stimuli in the environment until a match is made, which ultimately accesses the full-blown SEAP program.

Because the frontal lobe may be in a state of 5-HT₂ hypermetabolism and is fully occupied during a paraphiliac attack, uncontrollable release of the SEAP occurs.³⁹ There is thus, a complete loss of impulse control until orgasm completes the ritual. Once orgasm is reached, the patient can again gain impulse control, inhibition is restored and a profound sense of dysphoria overwhelms the patient, this is known commonly as GUILT. In the author's experience of many years, paraphiles never report guilt feelings during their paraphilic rituals, only afterward, and usually only after they are caught. The guilt comes from being caught, not from the paraphilic ritual behaviors. One possible core reason why the obsessive craving is so uncontrollable is that it may be driven by 5-HT₂ dysfunction which seems to be common to other OCD and spectrum disorders.⁴⁰

Clinical Correlation

A comparison may now be made to the original concept that obsessive-compulsive behavior is designed to reduce anxiety co-morbidly encoded with paraphilic disorders. In some paraphilias like raptophilia (rape), sadism, anger, violence, torture, and various types of brutality are

coded in the sexuo-erotic equation and are required for maximum arousal and orgasm. Because of its coding and relationship to probable 5-HT₂ dysfunction, this behavior can become obsessive and compulsive. In addition, because fear and or combinations of the above the obsessions are reinforced by sexual orgasm, the craving to act on the paraphilic obsession becomes virtually irresistible. Thus paraphilic SEAP rituals are a means to change any form of dysphoria or anxiety to euphoric orgasm. This creates a pathological condition in which the craving for sexual targets is obsessively and compulsively stalked in order to gratify the paraphilic craving. Patients suffering obsessive-compulsive paraphilological disorders are often so tortured, absorbed, and compulsively driven by their craving that the ordinary responsibilities of everyday life are left completely neglected. The author has noticed that many raptophiles and pedophiles are not continuously obsessive and compulsive; the active periods may be linked to biological variations in serotonin levels, mood, or hormonal variations and bio-social stressors.

From these observations, it is fairly reasonable to assume that the loss of impulse control in paraphilic disorders is related to 5-HT₂ disturbance in combination with sexual-erotic coding errors that probably occur during critical bio-social times in juvenile life. Impulse control is thought to be maintained by several species of serotonin, receptors, but 5-HT₂ seems to be a principle player.⁴¹ This conclusion is based on recent research that seems to show that 5-HT₂ appears critical for the maintenance of impulse control anxiety and obsessive-compulsive kinds of symptomatology.⁴²

In the author's unpublished research, six cases of chronic pedophilia were treated over a 40-week pilot trial with fluvoxamine and clomipramine hydrochloride, pedophilic craving was evaluated with a modified Y-BOCS. In all cases pedophilic

Obsessive-compulsive Paraphilias Viewed as a Sub Type (OCD) Spectrum Disorder

craving was reduced and maintained at the subclinical level. These results will be presented in a future article.

Sexual arousal and orgasm is the key feature of SEAP dynamics in paraphilic disorders. As mentioned in the earlier clinical case of a rapist, in childhood he had a sexually abused and brutalized mother. He witnessed numerous brutal and physically violent interactions between her and her numerous consort lovers. Thus, in his developmental history, violence, humiliation, and torture of the mother figure became cross coded into the service of arousal and orgasm which is permanently fused to sexual and erotic arousal. When asked about sexual stimulation under mild consensual conditions, this patient responded with a chuckled, "that would be boring as hell," he said, "to do it would be a severe compromise". Unfortunately, professionals and laymen alike still fail to realize that rapists, pedophiles and all other varieties of paraphiles, tremendously enjoy their 'kinky' sex, and that there is nothing psychological about it. The determining core factor is appetite, with a big capital (A).

In our example of an encoded rape Macro, humiliation, brutality, torture, pain, and violence for the rapist is a kind of sadistic foreplay, what ordinary people can't imagine because they don't carry an encoded Macro for that kind of sexual-erotic expression. The original encoded female, or in some cases, several females become the model, or template upon which the SEAP is forged. Victims who meet the pre determined SEAP criteria are often in jeopardy for their very lives, literally.

Rapists and pedophiles literally replicate what they have been encoded to do. The codes are so specific that most professionals are baffled by them and muddy the water with all kinds of intrapsychic explanations which, quite literally, have nothing to do with the sexual-erotic rituals of paraphiles at all. For example, one particular rapist known to the author typi-

cally fled from the scene of his rape to masturbate solo in concealment after the actual assault. Now why would that be? Actually the answer is quite simple. This individual often watched his mother's brutal lovers beat and sodomize her, through a hole in the wall that he secretly made. He would masturbate concealed from the actual players. This resulted is a pattern whereby, he would attack the victim, but he saved the orgasmic part of the ritual to do in solo masturbation. It is nothing more than experiential encoding or imprinting.

SEAP rituals are somewhat different than OCD rituals because they are far less socially stigmatizing. Nobody is going to call the police if they see a man picking garbage, or hoarding paper, but if a man is seen exposing himself genitally, he knows he could get locked up for ten or twenty years. In paraphilias, because of the social stigma, the patient tries to hold back the thoughts, behavior and fantasies, but as he does craving reaches unbearable levels until loss of impulse control occurs, which probably is generated by pathology in 5-HT₂ transmitter dynamics. It is postulated that the obsessive thoughts and rituals of a SEAP have a higher threshold for access compared to those of the OCD Macro because of the social and legal stigma and sanctions involved.

The Role of the Serotonin 5-HT₂ Receptor Family

We have mentioned serotonin numerous times in this article. Too much, or too little serotonin seems to cause problems among many species. In humans, it is related to anxiety and OCD disorders, in Leeches depletion stops feeding behavior. 5-HT projections of all families innervate all major regions of the CNS in man and is especially involved in sexual, and sensorimotor arousal. The 5-HT₂ family exerts their effects by increasing hydrolysis of phosphoinositol (PI) To date, there are fourteen types of 5-HT serotonin receptors, which are divided into seven

major families. Our focus is on 5-HT₂. It is fairly well established at this time that 5-HT₂ plays a pivotal role in OCD spectrum disorders. We will now explore its role in paraphiliological disorders with more detail. During the perseveration of the obsessive SEAP thoughts and fantasies accelerate with increasing intensity, and the patient suffers what we call, 'breakthroughs' (loss of thought or impulse control) that is, associations, thoughts and cognitions become looser, which is sometimes called, cognitive slippage. The patient can't concentrate clearly, focus begins slipping and the obsessive paraphilic thoughts and rituals become stronger and stronger until they take complete control of the patient's ability to think clearly at all. When this stage of paraphilic access occurs, the rapist, for example will begin stalking streets, parks malls, parking lots scanning for targets, the pedophile, on the other hand, will begin to cruise around arcades, school yards, parks, video stands anywhere his particular kind of targets are typically to be found. At this stage the paraphile is often desperately trying to talk himself out of the craving, which makes perfect sense, because, this is exactly what most therapists and professionals tell them to do. But it fails as the craving increases higher and higher, until complete paraphilic access occurs. By this point in time, the patient has no voluntary control of anything, consequences, jail, and the like mean absolutely nothing. After the complete paraphilic ritual is complete and orgasm has been achieved, the patient feels guilty because he could not stop what his paraphilic obsession demanded he do. He feels self pity, and is often depressed afterward, - can't understand why or how to control the monster within him. These are actual words and phrases recorded by chronic paraphiles over thousands of hours of clinical work.

The 'breakthroughs' and the cognitive slippage described appears to be related to

serotonergic depletion. It is fairly well established in OCD disorders, and the author suspects similar 5-HT₂ transmitter dynamics to be identified someday soon in the neurobiology of paraphiliological disorders

In OCD disorders, this conclusion is also supported by low levels of serotonin metabolite (5 hydroxyindoleacetic acid) found in the spinal fluid of patients with impulse and OCD spectrum disorders.⁴⁴ Further, support comes from the author's unpublished successful applications of SSRI compounds on patients with chronic pedophilic craving in pilot trials to be offered for publication soon. There seems to be a common link between OCD disorders and what the author has dubbed OCP, which is modulated by 5-HT₂, which may also involve cascading effects of other transmitters. Some 200 human brain transmitters and modulators have been cloned to date and it is not likely that any single transmitter functions alone. These multiple transmitter dynamics will have to be addressed in the future in their relationship to OCP and probably OCD spectrum disorders as well.

To date, it has been shown that the selective serotonergic re-uptake inhibitors (SSRI's) decrease OCD symptomatology.^{45,46,47,48} In fact, recent meta analysis studies on OCD may be cautiously applied to OCP. The only current treatment that produces significant lasting improvement is Behavior therapy and an SSRI except for neurosurgical procedures.^{49,50} It doesn't seem to difficult to design behavioral therapies for ordinary OCD disorders since they don't carry a legal or social stigma like the paraphiliological disorders do. Therefore, it is essential to consider the SSRI's in the long term management of these extremely debilitating disorders. There is convincing evidence that long term administration of SSRI's may enhance serotonin concentrations in the synaptic cleft by desensitizing 5-HT auto-receptors normalizing serotonergic function.

Obsessive-compulsive Paraphilias Viewed as a Sub Type (OCD) Spectrum Disorder

Summary

To summarize, the purpose of this paper is to provide a bio-medical model of what we have dubbed obsessive compulsive paraphilia, (OCP). The author hypothesizes that it is one of the spectrum of OCD anxiety disorders, which to date has not received any clinical attention as a clinical diagnostic disorder. Two major neuroanatomical sites have been identified in obsessive compulsive disorders, which the author hypothesizes may share co-morbidity with the OCD disorders. These sites are the septal-hippocampal behavioral inhibition system (BIS) and the prefrontal cortex-basal ganglia-thalamic 'Worry Circuit', both of which are linked by the well described Papez circuit. The cognitive and behavioral activities of the compulsive have been described as being similar in rigidity and sequence to the Macro of modern computer programs. Herein, it is postulated a Macro for OCP exists in paraphilological disorders defined as a Sexuo-Erotic Arousal Pattern (SEAP). Both OCD Macro's and SEAP Macro's are believed to result from specific neuromolecular encoding in juvenile life. SEAP codes are believed putatively stored in, or imprinted in the temporal lobe and other anatomical tissue of the brain ready for instant recall or access by the BIS under bio-social conditions dictated by the SEAP codes.

In conclusion, it is hoped that others will take the seminal suggestions offered, and go further and explore the use of SSRI's and some tricyclics (i.e.) clomipramine in particular in the long term management of the paraphilic disorders, one of the most debilitating and under represented bio-medical disorders in medical and psychiatric practice today.

References

1. American Psychiatric Association. Diagnostic and Statistical Manual of Mental Disorders, Fourth edition, Washington, DC American Psychiatric Association 1994
2. McElroy SL, Phillips KA, Keck PE Jr, Obsessive Compulsive Spectrum Disorders, J. Clin. Psychiatry 1994, 55 Vol, 10, Supp. Pg.42
3. Coleman E. Sexual Compulsivity: Definition, Etiology, and Treatment Considerations, In: Coleman, E. Ed. Chemical Dependency and Intimacy Dysfunction, New York, NY. Hayworth Press; 1987
4. McElroy SL, Phillips KA, Keck PE Jr, Obsessive Compulsive Spectrum Disorders, J. Clin Psychiatry 1994; 55 Vol, 10, Supp, pg. 43
5. Rasmussen SA, Tsuang MT, Clinical Characteristics and Family History in DSM-III Obsessive-Compulsive Disorders, Am J Psychiatry 1986; 143: 316-322
6. Anthony DT, Hollander E, Sexual Compulsions. In: Hollander E. Ed. Obsessive Compulsive Related Disorders, Washington, DC: American Psychiatric Press; 1993
7. Baxter, LR, Positron Emission Tomography Studies of Cerebral Glucose Metabolism in Obsessive Compulsive Disorder, J. Clin Psychiatry 1994; 55 Vol. 10, supp. Pgs. 54-59
8. Grey JA. The Neurobiology of Anxiety, First Edition, New York, NY: Oxford University Press;1982
9. McElroy SL, Phillips KA, Keck PE Jr, Obsessive Compulsive Spectrum Disorder. J. Clin. Psychiatry 1994; 55 Vol 10, Supp, Pg. 34
10. McElroy SL, Phillips KA, Keck PE Jr, Obsessive Compulsive Spectrum Disorder J. Clin. Psychiatry 1994; 55 Vol. 10, Supp Pg. 42
11. Baxter, LR, Positron Emission Tomography Studies of Cerebral Glucose Metabolism in Obsessive Compulsive Disorder J. Clin Psychiatry 1994; 55 Vol 10, Supp Pg. 58
12. Grey JA, The Neurobiology of Anxiety, First Edition, New York, NY: Oxford University Press; 1982, Pg. 11
13. Grey JA, The Neurobiology of Anxiety, First Edition, New York, NY: Oxford University Press; 1982, Pg. 440
14. Audio Digest Psychiatry Vol. 21 No. 21 Vol #1. OCD A Review of its Phenomonology and its infuence on Diagnosis. Steven A. Rasmussen, M.D. 1995
15. Lorenz K. King Solomon's Ring, Thomas Cromwell, New York 1952
16. Lorenz K. Aggression, Harcourt Brace World, New York 1963
17. Tinbergen N. Early Childhood Autism: An Ethological Approach Comparative Ethol 10 Supp. 9 1972
18. Montarola PG, Kandel ER, Schacher S, Long-Term Heterosynaptic Inhibition in Aplysia Nature 333 1988 Pg. 171-174
19. Kuno, Motoy, The Synapse: Function, Plasticity and Neurotropism; Oxford University Press 1995 Pg. 38

20. Yeh Shih-Rung, Fricke RA, Edwards DH, Sci Jan. 1996 Vol, 271 Pg 366-369
21. Singer W, Development and Plasticity of Cortical Processing Architectures, Sci. Nov. 1995; Vol 270, Pg 158-164
22. Bremer JD, The American Journal of Psychiatry July 1995
23. Shepard G, Neurobiology; Oxford University Press, New York, 1994
24. Harrison's Principles of Internal Medicine Wilson JD, Braunwald E, Isselbacher KJ, Petersdorf RG, Martin JB, Fauci AS, Root RK, Eds, 12 Ed New York; McGraw-Hill, 1991 Pg 201
25. Grey JA, The Neurobiology of Anxiety, First Edition, New York; Oxford University Press; 1982. Pg 12
26. Baxter, LR, Positron Emission Tomography Studies of Cerebral Glucose Metabolism in Obsessive Compulsive Disorder. J Clin Psychiatry 1994; 55 L 10, Supp, Pg 54-59
27. Papez J.. A Proposed Mechanism of Emotion Arch Nerol Psy Chiat 1938 Pg 725-743
28. Grey JA, The Neurobiology of Anxiety, First Edition, New York; Oxford University Press; 1982. Pg. 294
29. Grey JA, The Neuropsychology of Anxiety, First Edition, New York, NY: Oxford University; 1982. Pg. 459 - 461
30. Grey JA, The Neuropsychology of Anxiety, First Edition, New York, NY: Oxford University; 1982. Pg. 92
31. Baxter, LR, Positron Emission Tomography Studies of Cerebral Glucose Metabolism in Obsessive Compulsive Disorder. J. Clin Psychiatry 1994; 55 Vol. 10, Supp. Pg. 58
32. Baxter, LR, Positron Emission Tomography Studies of Cerebral Glucose Metabolism in Obsessive Compulsive Disorder. J. Clin Psychiatry 1994; 55 Vol. 10, Supp. Pg. 57
33. Kaplan HI, Freedman AM, and Sadock BJ, Comprehensive Textbook of Psychiatry. Third Edition. Vol 2, Williams and Wilkins. Baltimore London 1980 Pg. 57
34. Grey JA, The Neuropsychology of Anxiety, First Edition. New York, NY: Oxford University Press; 1982 Pg. 453
35. Grey JA, The Neuropsychology of Anxiety, First Edition. New York, NY: Oxford University Press; 1982 Pg. 436
36. Eison MS, Stark AD, Ellison G. Opposed Effects of Locus Coeruleus and Substantia Nigra Lesions on Social Behavior in Rat Colonies. Pharmac. Biochem. Behavior 1977: Vol. 7, Pg. 87 - 90
37. Grey JA, The Neuropsychology of Anxiety, First Edition. New York, NY: Oxford University Press; 1982 Pg. 436
38. Baxter, LR, Positron Emission Tomography Studies of Cerebral Glucose Metabolism in Obsessive Compulsive Disorder. J. Clin Psychiatry 1994; 55 Vol. 10, Supp. Pg. 58
39. Grey JA, The Neuropsychology of Anxiety, First Edition. New York, NY: Oxford University Press; 1982 Pg. 454
40. Kate RJ, Neurobiology of Obsessive-Compulsive Disorder - A Serotonergic Basis of Freudian Repression. Neurosci, and Biobeh. Rev., 1991, Vol. 15, Pg. 375 - 381
41. Stein DJ, Hollander E, Anthony DT, et, al. Serotonergic Medication for Sexual Obsessions, Sexual Addictions, and Paraphilias. J. Clin. Psychiatry 1992: Vol. 53, Pg. 267 - 271
42. Relapse Prevention. Safer Society Press, Brandon, Vermont
43. Gibbs WW, Seeking the Criminal Element. Sci, Am., March 1995. Pg. 100 - 107
44. Fountaine R, Chouinard G, Fluvoxamine in Obsessive Compulsive Disorder. Psych. Ann. 1989, Vol. 19 No. 2 Pg. 92 - 96
45. Kafka MP, Successful Treatment of Paraphiliac Coercive Disorder (A Rapist) with Fluoxetine Hydrochloride. Br. J. Psychiatry 1991; Vol. 158: Pg. 844 - 847
46. Emmanuel NP, Lydiard RB, Ballenger JC, Fluoxetine Treatment of Voyeurism (Letter) Am. J. Psychiatry. 1991; 148 - 950
47. Bianchi MD, Fluoxetine Treatment of Exhibitionism (Letter) Am. J. Psychiatry 1990; Vol. 147, Pg. 1089 - 1090
48. Goodman WK, Price LH, Delgado PL, et. al. Specificity of Serotonin Reuptake Inhibitors in the Treatment of Obsessive-Compulsive Disorders: Comparison of Fluvoxamine and Desipramine. Arch. Gen. Psych. 1990; Vol. 45, Pg. 577 - 585
49. Greist JH, Jefferson JW, Kobak K, et.al. Efficacy and Tolerability of Serotonin Transport Inhibitors in Obsessive-Compulsive Disorder: A Meta Analysis. Arch. Gen. Psychiatry 1995; Vol. 52. Pg. 53 - 60
50. Murphy DL, Pigott TA. A Comparative Examination of a Role for Serotonin in Obsessive-Compulsive Disorders, Panic Disorder and Anxiety. J. Clinical Psychiatry 1990; Vol. 51 (4 Supp). Pg. 53 - 58
51. Leonard BE. The Comparative Pharmacology of New Anti-depressants. J. Clin. Psychiatry 1993; Vol. 54 (8 Supp). Pg. 3 - 15
52. Christensen H, Hadzi-Pavlovic D, Andrews G, et. al., Behavior Therapy and Tricyclic Medication in the Treatment of Obsessive-Compulsive Disorder: A Quantitative Review. J. Consulting Clinical Psychology 1987; Vol. 55, Pg. 707 - 711

PAPEZ CIRCUIT

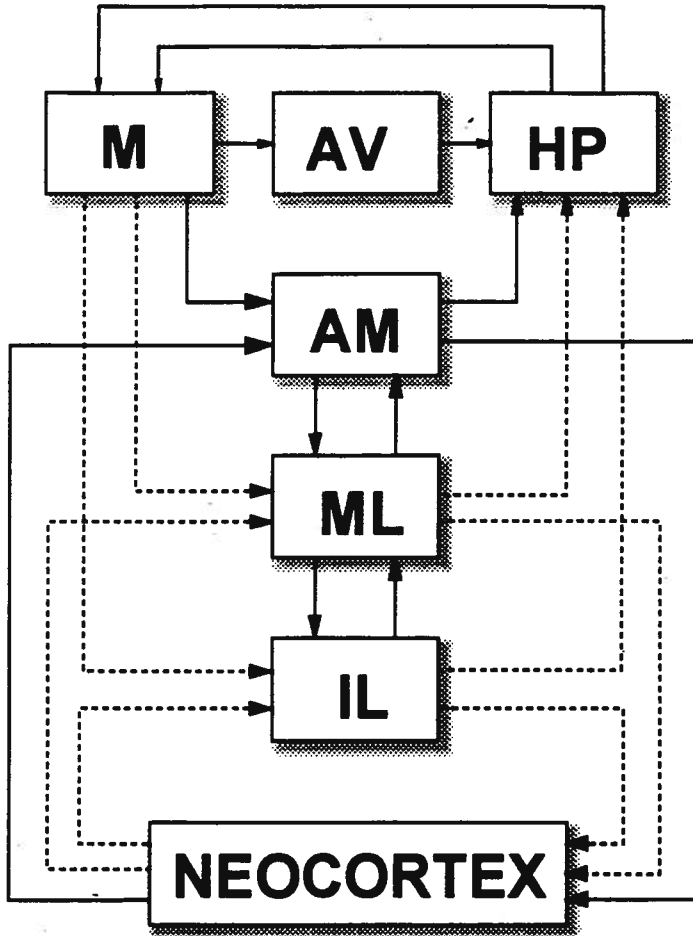

THALMO-NEOCORTICAL CIRCUIT

